

Section I

SUSPENSION (FRONT SUSPENSION)

DATA AND SPECIFICATIONS

FRONT HEIGHT SPECIFICATIONS

MC-1, MC-2, MC-3 and MY-1.....	2 $\frac{1}{8}$ " + or - $\frac{1}{8}$ "
Town and Country Models and Cars Equipped with Heavy Duty Springs.....	2 $\frac{1}{2}$ " + or - $\frac{1}{8}$ "

On Cars With True-Level Torsion Aire

MC-1, MC-2, MC-3.....	1 $\frac{7}{8}$ " + or - $\frac{1}{8}$ "
MY-1.....	2 $\frac{1}{8}$ " + or - $\frac{1}{8}$ "

CASTER AND CAMBER WITH MANUAL STEERING

Caster	Camber	Steering Axis Inclination	Toe-In
- $\frac{3}{4}$ ° ± $\frac{3}{4}$ °	0° ± $\frac{1}{4}$ ° (right) + $\frac{1}{4}$ ° ± $\frac{1}{4}$ ° (left)	5° to 7° At 0° Camber	$\frac{1}{8}$ " ± $\frac{1}{32}$ " ($\frac{1}{8}$ " Preferred)

WITH POWER STEERING

Caster	Camber	Steering Axis Inclination	Toe-In
+ $\frac{3}{4}$ ° ± $\frac{3}{4}$ °	0° ± $\frac{1}{4}$ ° (right) + $\frac{1}{4}$ ° ± $\frac{1}{4}$ ° (left)	5° to 7° At 0° Camber	$\frac{1}{8}$ " ± $\frac{1}{32}$ " ($\frac{1}{8}$ " Preferred)

REAR SUSPENSION

REAR SPRINGS

	MC-1		MC-2		MC-3		MY-1
	Sedans & Coupes	Town & Country	Sedans & Coupes	Sedans & Coupes	Town & Country	Sedans & Coupes	
Type.....	Semi-Elliptic	Semi-Elliptic	Semi-Elliptic	Semi-Elliptic	Semi-Elliptic	Semi-Elliptic	
Length.....	57"	57"	60"	60"	60"	60"	
Width.....	2.5"	2.5"	2.5"	2.5"	2.5"	2.5"	
Number of Leaves—Std. Susp.....	5	6	6	7	7	7	
Rate—Std. Susp.....	95 # per in.	125 # per in.	90 # per in.	90 # per in.	135 # per in.	90 # per in.	
Number of Leaves—True-Level.....	5	5	6	6	7	6	
Rate—True-Level.....	80 # per in.	95 # per in.	75 # per in.	75 # per in.	100 # per in.	83 # per in.	

REAR SUSPENSION (Cont'd)

FRONT PIVOT	Silent Block Rubber Bushings
REAR	Shackle with Rubber Bushing

SHOCK ABSORBERS

TYPE	Oriflow, Double Acting Hydraulic
------	----------------------------------

TRUE-LEVEL TORSION AIRE

CAR REAR HEIGHT (Axle Housing to Frame)	
Imperial Models Only	4 $\frac{3}{8}$ + or - $\frac{1}{8}$ inch
MC-1, MC-2, MC-3 Models Only	4 $\frac{3}{4}$ + or - $\frac{1}{8}$ inch
HEIGHT CONTROL VALVE	
Make	Midland-Ross
Type	Bleed-Feed
AIR PRESSURE	
High Pressure Tank	220 + or - 20 psi
Low Pressure Volume Tank (1 pass. load)	20 psi approximately
(6 pass. load)	70 psi approximately
(9 pass. load)	90 psi approximately
COMPRESSOR	
Make	Tecumseh
Type	Balanced Head

TORQUE SPECIFICATIONS

	Pounds Torque
AIR LINE	
Elbow Mounting Screw	100 in. lbs.
High Pressure Tank to Low Pressure Tank Height Control Valve Tube Nuts (4)	85 in. lbs.
Air Hose Assembly to High Pressure Tank Tube Nut	125 in. lbs.
Compressor Check Valve to Air Hose Assembly Tube Nut	90 in. lbs.
Compressor to Air Line Check Valve	130 in. lbs.
AIR SPRING	
Retainer Bolt Nut	10 ft. lbs.
COMPRESSOR	
Adjusting Strap Bolts	30 ft. lbs.
Adjusting Strap to T-Nut Bolt	15 ft. lbs.
Bracket to Support Bolt	30 ft. lbs.
Bracket to Air Conditioning Compressor Bolt Nut	30 ft. lbs.
Cylinder Head Bolt	155 in. lbs.
Front Bearing Housing Bolt	17 in. lbs.
Oil Inlet Connector	130 in. lbs.
Rear Cover Plate Bolt	17 in. lbs.
Strap Bolt Nut	35 ft. lbs.
Suction Muffler Retaining Screw	17 in. lbs.
Support Bracket to Water Pump Body (or Cylinder Block or Cylinder Head Bolt)	30 ft. lbs.
Support to Cylinder Head Bolt	70 ft. lbs.

TORQUE SPECIFICATIONS (Cont'd)

	Pounds Torque
HEIGHT CONTROL VALVE	
Axle Housing Link Bracket Bolt Nut.....	30 ft. lbs.
Minimum Pressure Valve.....	130 in. lbs.
Mounting Nuts.....	100 in. lbs.
HIGH PRESSURE TANK	
Drain and Charging Valve.....	140 in. lbs.
Mounting Bolts ($\frac{5}{16}$).....	10 ft. lbs.
Mounting Bolts ($\frac{1}{4}$).....	100 in. lbs.
LOW PRESSURE VOLUME TANK	
Mounting Bracket Screw.....	100 in. lbs.

TOOL LIST

C-3128.....	Snap Ring Pliers
C-3293.....	300 lb. Pressure Gauge
C-3569.....	Detector Torch
C-3670.....	Air Spring Height Gauge
C-3677.....	Crankshaft Support Stand
C-3680.....	Front Oil Seal Protector
C-3693.....	Adapter—used with Tool C-3293, 300 lb. pressure gauge
C-3694.....	Hold-Down Straps (Pr.)
PO-11.....	Pulley Puller

Section I

SUSPENSION (FRONT SUSPENSION)

The new upper control arm and frame brackets simplify the method of adjusting caster and camber. Tool C-3669 is required for installation of upper control arm bushings.

OPERATION (FIG. 1)

The upper control arms attach to brackets which are welded to the frame. Each bracket has cam retainers welded to its front and rear faces, around the slotted openings for the attaching bolts. Each of the four bolts have an integral cam **at the head of the bolt**. A matching removable cam is installed at the threaded end.

Cams can be adjusted only by turning the head end of the bolt. Turning one bolt will move the upper ball joint fore or aft to affect the caster (more than camber). Turning both bolts on one side an equal amount in the same direction will move the upper ball joint in or out to affect camber. Full bolt travel is 180°, therefore it may be necessary to reverse the direction of rotation of the bolts in order to attain specifications on both caster and camber.

ADJUSTMENT

Apply MoPar solvent, Part No. 1879318, after wire brushing dirt to expose bolt threads. In addition to

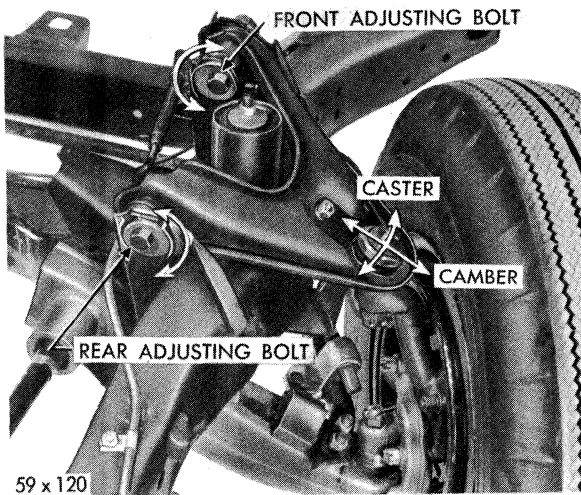

Fig. 1 — Caster and Camber Adjusting Bolts

the regular checks of tire size, tread wear, air pressure, car loading, looseness and wear before measuring car height, caster and camber, the car must be kept at one level whenever measurements are made. Do this operation the same way every time a measurement is to be made: bounce the car, front first, then rear, several times by grasping the center of the bumpers. Release the bumpers on the down stroke each time after the same number of bounces.

All Chrysler Models with True-Level Torsion Aire must maintain the specified rear height of $4\frac{3}{4}$ inches + or - $\frac{1}{8}$ inch, the Imperial (MY-1), rear height if $4\frac{3}{8}$ + or - $\frac{1}{8}$ inch while setting the front end, with engine running (see True-Level Torsion Aire).

REAR SUSPENSION

REAR SPRINGS

The rear springs remain the same with the following exception: the springs have a rubber pad between the springs and the axle housing. The "U" bolt nut torque is 70 + or - 15 foot-pounds.

SHOCK ABSORBERS

The 1959 model cars are equipped with Oriflow shock absorbers of the same type as used on the 1958 mod-

CASTER AND CAMBER

Front suspension height must be correct before measuring caster and camber.

After Solvent No. 1879318 has loosened any rust, carefully loosen the upper control arm attaching nuts while holding the bolts from turning. Once caster and camber has been adjusted, a very small turn of the bolts will affect the gauge readings.

Turning one bolt affects caster more than camber. By bringing caster to approximate specifications, then turning both bolts an equal amount in the same direction to bring camber to the preferred specification, will usually bring caster to the preferred setting. Tighten nuts to 60-70 foot pounds torque using Tools C-3675 and C-3696. However, due to length of Tools C-3675 and C-3696 used with torque wrenches Tool C-524 or Tool C-3005 a recalibration will be necessary in order to obtain proper torque. Using Tool C-3675, the torque reading on wrench must show 45 foot-pounds torque, which is equivalent to 60-70 foot-pounds torque; and using wrench C-3696, torque reading must be 55 foot-pounds torque, which again is equivalent to 60-70 foot-pounds torque. Re-check gauge readings.

NOTE: Turning both cams in the same direction an equal amount will change camber with little or no change of caster. Turning both cams an equal amount in opposite directions will change the caster with little or no change of camber.

els. Refer to the 1958 Chrysler and Imperial Manual, D-16350, for information on the removal and installation of the Oriflow shock absorbers.

CAUTION

When car is equipped with True-Level Torsion Aire, do not use a frame contact type hoist when removing shock absorbers, as the air springs will become unseated from the upper spring seat.

TRUE-LEVEL TORSION AIRE

The True-Level Torsion Aire System (Figs 2 and 3) available as optional equipment on the 1959 Chrysler and Imperial cars consists of an engine driven balanced head compressor, compressor drive belt, check valve, high pressure air lines, high pressure reservoir tank, low pressure volume tank, height control

valve assembly, air springs and valve (actuating) rubber linkage.

On cars equipped with True-Level Torsion Aire System, conventional steel semi-elliptic leaf springs and shock absorbers are used, however, spring load and rate have been reduced approximately ten per cent.

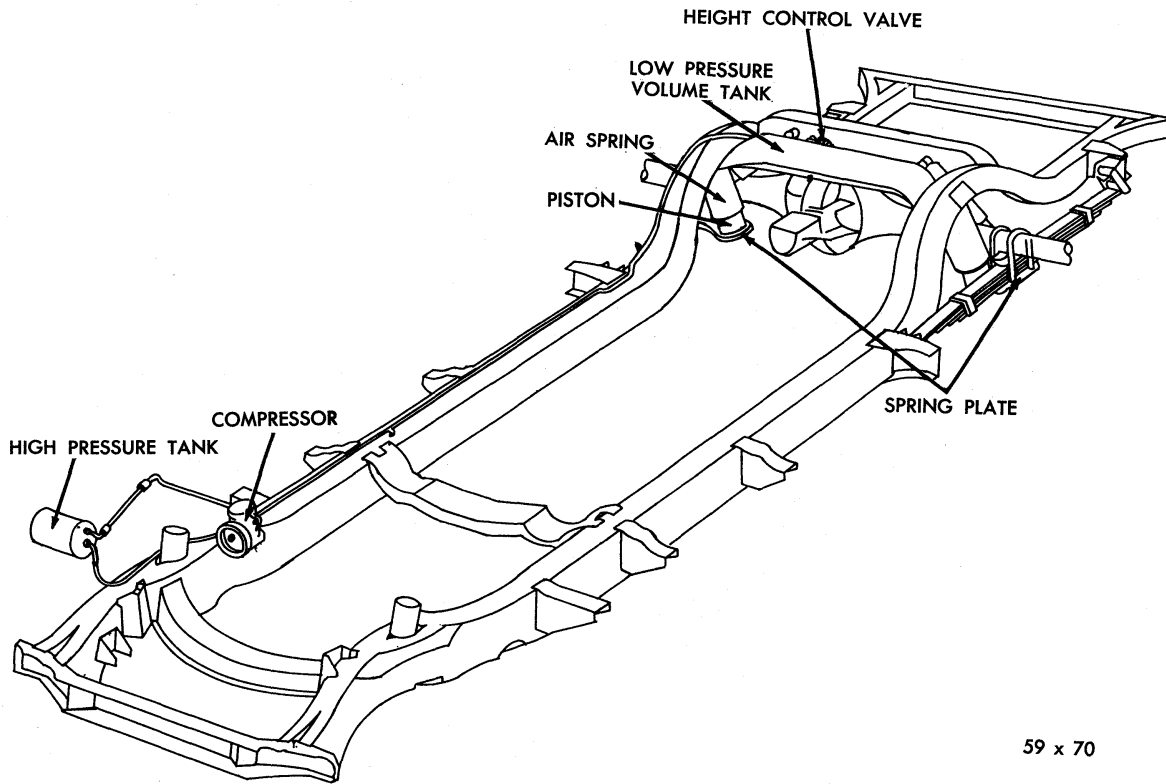

59 x 70

Fig. 2 — True-Level Torsion Aire System (Models MC-1, 2 and 3)

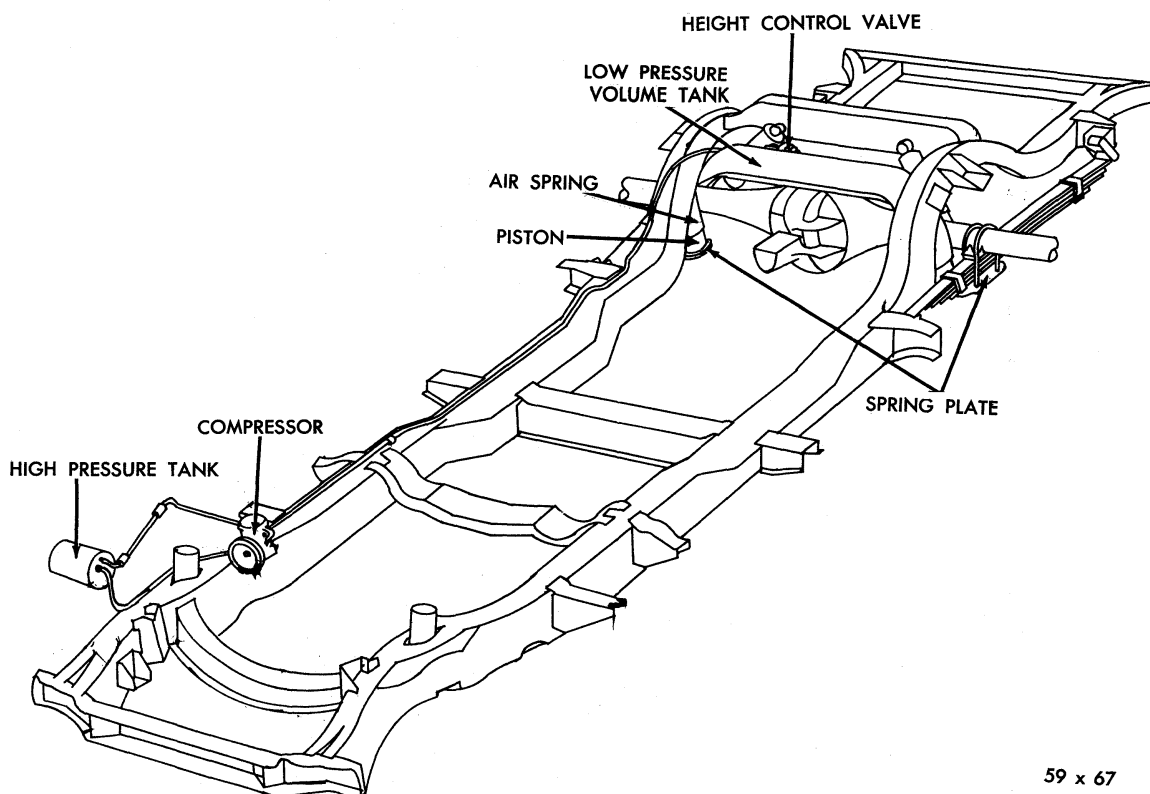

59 x 67

Fig. 3 — True-Level Torsion Aire System (Model MY-1)

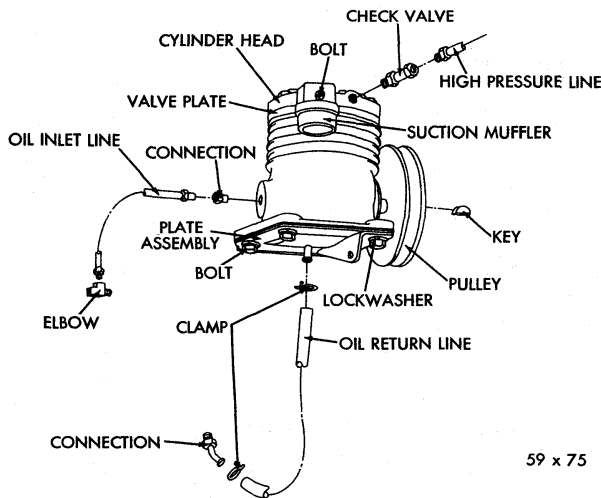

59 x 75

Fig. 4 — Compressor Assembly

True-Level Torsion Aire produces a better quality ride as well as maintaining a constant rear height. The rear height is comparable to that of a car without True-Level Torsion Aire and with a three passenger load.

The compressor (depending on car model) (Fig. 4) is located either at the front of the engine or above the fuel pump. The check valve is located in the compressor head. A high pressure line from the

check valve is connected to the high pressure reservoir tank under the right front fender. A second high pressure line connects the high pressure tank to the height control valve (Fig. 5) on the low pressure volume tank. The low pressure volume tank is mounted between the frame side rails above the rear axle. Two air springs from the low pressure volume tank are connected to the two air spring pistons on the rear spring plates. The height control valve actuator arm is connected to the rear axle assembly by a rubber link.

OPERATION

With the engine running, the compressor maintains 220 + or - 20 psi air pressure through the air lines and high pressure tank to height control valve end cap. (The amount of pressure is determined in the design of the balanced head.) The check valve at the compressor and the control valve confine the high pressure when the engine is stopped.

The operating pressure in the low pressure volume tank and air springs is controlled by the height control valve. The pressure varies with the load, from approximately 20 psi with or without a driver only load, through 70 psi with six passenger load to approximately 90 psi for the Town and Country models with a nine passenger load. Pressures within

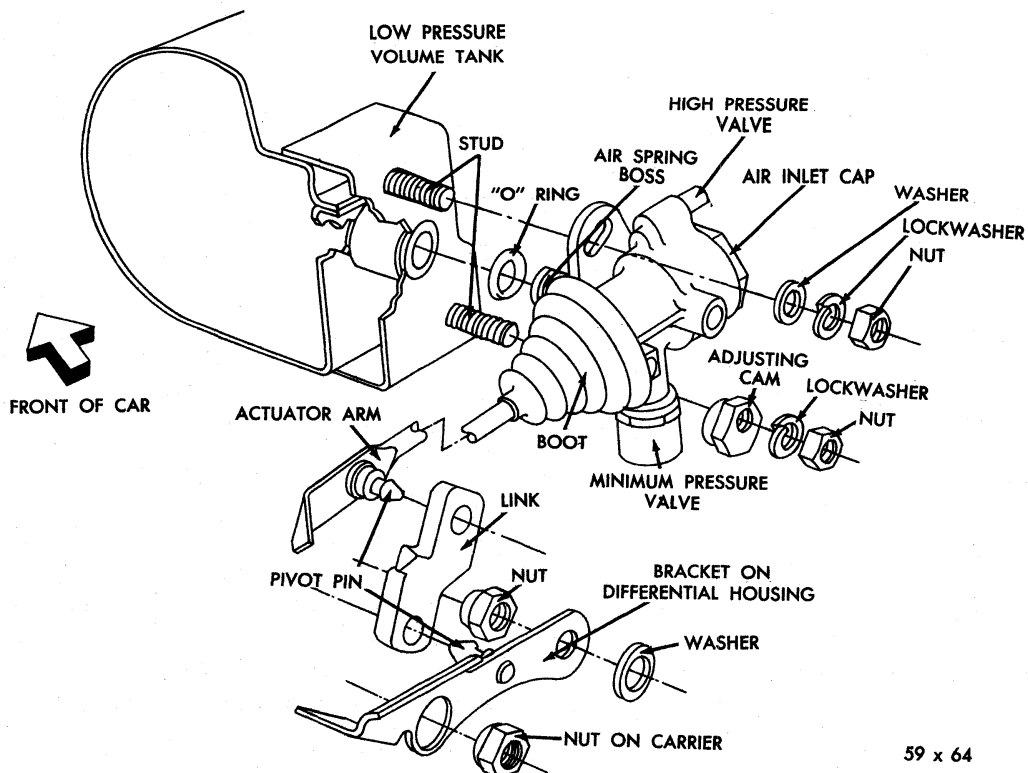

59 x 64

Fig. 5 — Height Control Valve

this range vary instantly as the car moves over chuck holes and expansion strips in the road surface, in order to maintain the constant rear height. Since these pressures are variable, it is not necessary to test them.

The height control valve contains a minimum pressure valve to maintain 8-15 psi in the air springs

during a no-load operation as in changing tires by use of a bumper jack. This pressure prevents damage to the air spring as the jack is lowered and a load condition restored to the system.

The height control valve also contains a high pressure relief valve (150 psi) to protect the system under extreme heavy load conditions.

SERVICE PROCEDURES

MAINTENANCE

The high pressure air tank (located under the right front fender) should be drained at least once a month. Depress the non-removable core in the drain valve. (Should it ever be necessary to remove the valve, remove the high pressure line at the check valve FIRST.)

TESTING FOR LEAKS (Liquid Soap Method)

With the engine running, apply a diluted liquid soap solution at the following locations where leaks would cause bubbles: air springs and seats, height control valve mounting, air line connections, high pressure air tank, drain valve connection and outlet.

Stop the engine and remove the air line and check valve from the compressor. Connect the air line and check valve. Apply air pressure through the tank drain valve. Coat check valve with soap solution. If no leak is evident, wipe off soap solution before re-installation.

Refrigerator Method (Refrigerant 12)

Add 150 pounds of weight to the center area of the luggage compartment and raise car on a hoist. Discharge the high pressure tank by depressing the valve core in the valve. Remove the minimum pressure valve from the height control valve. Disconnect the rubber linkage from the differential housing bracket and move the actuator arm manually to discharge all air from the low pressure volume tank. With all air removed from the system, connect the rubber linkage and install the minimum pressure valve.

Install adaptor Tool C-3693 between the high pressure air line and the compressor check valve. Connect manifold gauge set, Tool C-3627 (used with air conditioning) on adaptor, Tool C-3693, using the gauge set suction hose. Attach the refrigerant tank to the gauge set. Open the suction side of the gauge set and charge the system with 40 psi of refrigerant 12. Shut off the gauge set and start the car

engine. Operate the car engine until normal operating pressure of 200 + or - 20 psi is obtained.

Using leak detector, Tool C-3659, (used with air conditioning) check the entire True-Level Torsion Aire System for leaks and make all necessary repairs.

CAUTION

Be sure no gasoline is leaking from the car system when checking the True-Level Torsion Aire System with Tool C-3659.

With the car engine running, purge the refrigerant from the system by disconnecting the rubber linkage from the differential housing and manually operating the height control valve actuator arm. With the refrigerant purged from the system, connect the rubber linkage to its bracket. Shut off the car engine and again discharge all air from the high pressure tank. Remove adaptor Tool C-3693 from the air line and check valve. Connect the air line to the check valve. Lower the hoist and remove the weight from the luggage compartment. Operate the car engine approximately three minutes before removing the car from the hoist.

CHECKING AND ADJUSTING SUSPENSION HEIGHT

The vehicle must have recommended tire pressures, full tank of fuel (or equivalent weight added to luggage compartment over the tank). (Gasoline weighs approximately 6½ pounds per gallon.) The front suspension height should be correct and equal on both sides before placing car on level floor with no passenger load.

The rear suspension height must be set to a specified vertical distance between the top of the axle housing and highest part under the axle bumper straps, to the rear of the rubber bumpers on both sides of the car (Fig. 6). Clean the bumper straps and axle housing tubes before measuring.

Rear suspension height is measured (both sides) twice, once with load and again without load. Both pairs of figures are compared as well as averaged.

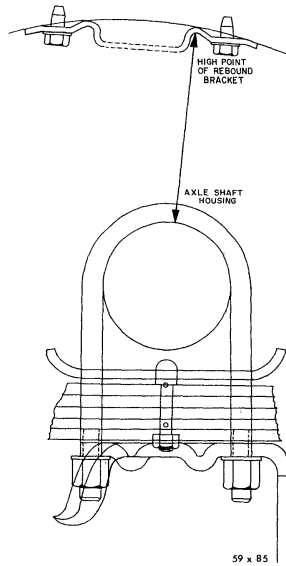

Fig. 6 — Checking Rear Suspension Heights

The four figures are also averaged. Run the engine three to five minutes to assure proper pressure in the system and proceed as follows:

a. With engine running, add 150 to 200 pounds of load to center of luggage compartment. The height control valve should feed additional air to the low pressure system, causing car to return to original height.

Measure height at both sides using Tool C-3670, and record the figures. The difference should not exceed 1/2 inch. If greater than 1/2 inch, recheck the front suspension height, particularly the difference between the two sides, and reset if necessary. If rear height difference still exceeds 1/2 inch, inspect rear springs. (for spring specifications in this supplement). When difference is under 1/2 inch, average the two figures for use later. This is Step (a).

b. Remove added weight from compartment and allow height control valve to bleed the system for approximately three minutes. The engine may be shut off during this operation.

Measure rear heights and average the two figures. The difference between this average and the average obtained in step (a) above should not exceed 1/2 inch. (This difference is called the height control valve correction error.) Adjust valve if necessary.

Average the four measurements. (Do not average the two averages.) The average should be 4 3/4 inches + or - 1/8 inch on Models MC-1, MC-2, MC-3 and 4 3/8 inches + or - 1/8 inch on Model MY-1. Adjust valve if necessary.

To adjust height control valve: Loosen both at-

taching nuts. Rotate cam on lower attaching stud to adjust to correct car height. **DO NOT BOTTOM CAM TIGHTLY AGAINST VALVE BODY.** (LOW PRESSURE VOLUME TANK PORT COULD BE DAMAGED.) Tighten attaching nuts to 100 inch pounds torque. Recheck rear suspension heights.

DISCHARGING THE SYSTEM

CAUTION

Do not use a frame contact type hoist when discharging system.

Discharge the high pressure system by depressing the valve core in the high pressure air tank drain and charging valve. **DO NOT REMOVE VALVE FROM TANK.**

Discharge low pressure system by pulling the height control valve actuator arm off the pivot pin on the rubber linkage at the axle housing and moving the arm down.

AIR SPRINGS AND PISTONS

CAUTION

During jacking operations, the minimum pressure valve must retain pressure in air springs to prevent buckling.

Removal and Disassembly (Fig. 7)

With car on hoist, refer to paragraph "Discharge the System." Remove nut holding air spring piston to spring plate. Raise piston off spring plate and remove air spring from low pressure volume tank by pulling it outward and down.

Remove piston mounting bolt and retainer assembly from piston using a soft mallet. Push piston out of air spring by inserting hammer handle (or equivalent) into the air spring.

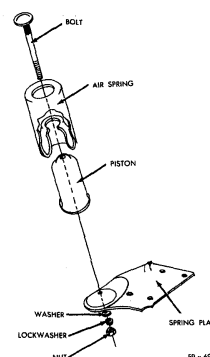

Fig. 7 — Air Spring and Piston Assembly

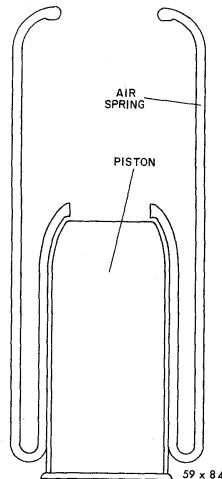

Fig. 8 — Installing Air Spring on Piston

CAUTION

Under no circumstances should the small end of the air spring be pulled out to a fully extended position, as special tools are required to place in correct position.

Cleaning and Inspection

Clean all parts with clean, dry cloth. Inspect piston and mounting bolt assembly for nicks, burrs or cracks. Remove burrs with crocus cloth. Replace a cracked piston with a new piston.

Mounting bolt assembly must be a snug fit in piston and retainer section must seat solidly against piston. If necessary, peen piston around bolt hole to obtain snug fit.

Inspect air spring for cuts, cracks, holes and excessive carcass wear. Install a new air spring if necessary, however, small surface cracks in outer rubber cover are permissible provided there is no leak.

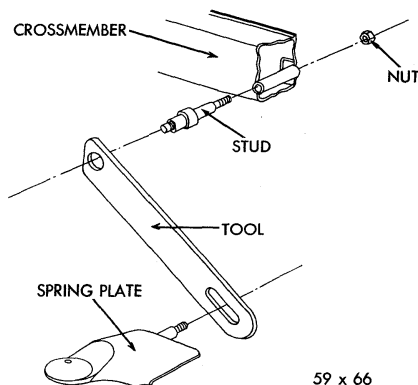

Fig. 9 — Body to Frame Hold Down Straps

Reassembly and Installation

With piston upright on bench, place small end of air spring over rounded end. Roll spring down to cover piston completely (Fig. 8). Insert retainer bolt assembly and examine for snug fit in piston.

Remove rear shock absorbers. Make hold down straps or use Tool C-3694 straps (Fig. 9) and install them in place of shock absorbers. Strap will hold weight of body on leaf springs and assist in seating air spring.

Position piston and air spring assembly on spring plate. Install retainer bolt, washer and nut (Fig. 10). Tighten to 5 foot-pounds torque temporarily. Coat mounting rim of air spring with diluted liquid soap. If both springs were removed from the low pressure volume tank, it will be necessary to install both simultaneously.

Start the engine. Hold air spring (s) tightly in position against tank seat (s) and operate control valve manually. Air pressure entering air spring (s) will force spring up on its seat.

Check seating of air spring on tank flange and seating of piston on spring plate. Align piston and tighten nut to 100 inch-pounds torque. Piston alignment can be checked by depressing around wall of air spring and noting if piston is properly centered. Remove hold down straps and install shock absorbers. Connect actuator arm to rubber linkage. Check for air leaks paragraph "Testing for Leaks." Check car heights.

RUBBER LINKAGE

The rubber linkage which connects pivot pins on the valve actuator arm and the bracket on the axle housing is removed by pulling the linkage off the pivot pins.

Before installing, apply water or soap solution

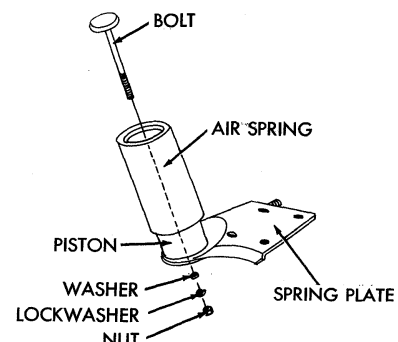

Fig. 10 — Installing Air Spring and Piston Assembly

around pivot pin holes. Position linkage with rounded end up toward actuator arm and stop boss to the left side of car. Push linkage on pivot pins.

HEIGHT CONTROL VALVE (Fig. 5)

a. Removal

Refer to paragraph "Discharging the System." Remove high pressure line from valve end cap. Remove valve mounting nuts and remove valve assembly.

NOTE: Height control valves are serviced only as an assembly.

The "O" ring valve to low pressure volume tank seal is serviced separately.

b. Installation

Apply diluted liquid soap to "O" ring on housing boss. Install valve assembly on low pressure volume tank, inserting the boss in tank without damaging the "O" ring. Install adjusting cam in housing at the lower mounting stud.

Install mounting nuts finger tight. Connect air line to valve end cap. Start the engine and check the valve for operation.

Tighten mounting nuts to 100 inch pounds torque. Connect actuator arm to rubber linkage. Check for leaks, refer to paragraph "Testing for Leaks." Check car height, paragraph "Checking and Adjusting Suspension Height" and adjust as necessary.

LOW PRESSURE VOLUME TANK (Fig. 11)

a. Removal

Discharge the system. Remove air springs from tank by pulling top of springs downward and outward. Disconnect air line at valve end cap. Disconnect actuator arm at rubber linkage. Loosen and lower

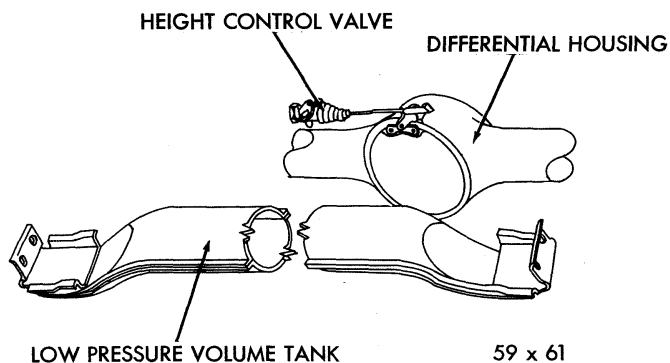

Fig. 11 — Low Pressure Volume Tank

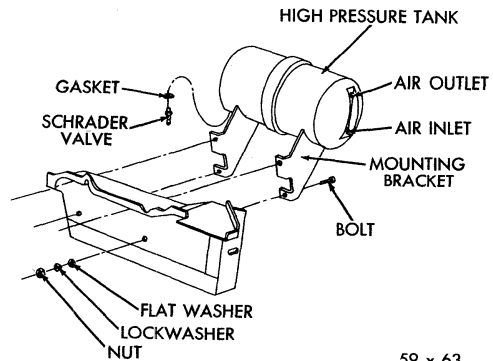

Fig. 12 — High Pressure Tank (Models MC-1, 2 and 3)

right tail pipe only.

Support axle and remove right rear wheel. Remove self-tapping screws (two each side) holding tank to frame side rails. Remove tank from right side of car. Remove height control valve assembly and adjusting cam.

b. Installation

Install new "O" ring on height control valve air spring boss. Coat ring with diluted liquid soap solution. Install valve assembly and adjusting cam. Tighten nuts to 100 inch pounds torque. Install tank making sure that insulating pads are in position between frame and tank mounting flanges. Tighten mounting screws to 100 inch pounds torque.

Connect air line to control valve. Install air springs paragraph "Air Springs and Pistons." Position and tighten right tail pipe. Install right rear wheel. Check system for leaks. Adjust car rear height.

HIGH PRESSURE AIR TANK (Figs. 12 and 13)

a. Removal

Discharge the system. Disconnect both air lines at tank. Remove bolts holding tank cradle to the car. Remove tank and bracket assembly.

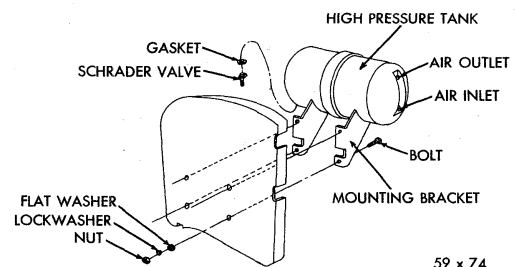

Fig. 13 — High Pressure Tank (Model MY-1)

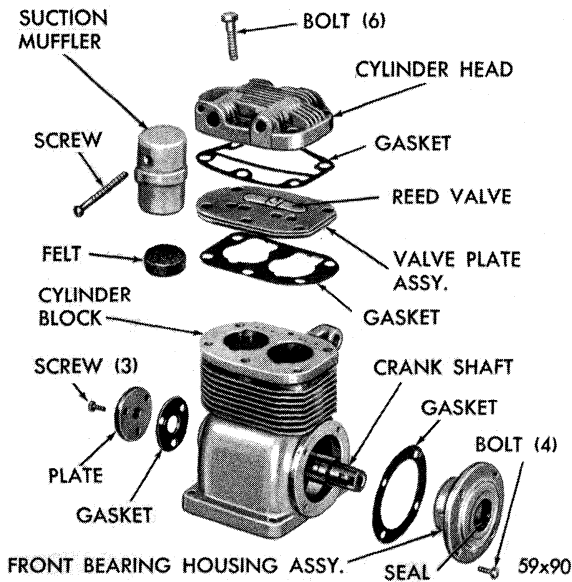

Fig. 14 — Air Compressor (Disassembled View)

b. Installation

Position tank and bracket assembly and install bolts. Tighten 1/4 inch bolts to 100 inch pounds torque, and 5/16 inch bolts to 130 inch pounds torque. Connect air lines to tank. Check for leaks.

AIR COMPRESSOR (Fig. 14)

a. Testing Compressor

Discharge the system. Disconnect air line from compressor check valve. Connect adapter, Tool C-3693, used with Tool C-3293, 300 lb. pressure gauge, to check valve.

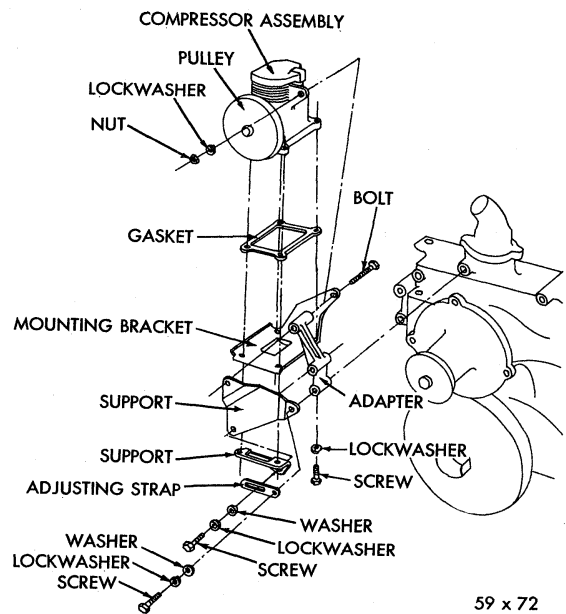

59 x 72

Fig. 16 — Compressor Mounting (with Air Conditioning (Models MC-2, 3 and MY-1)

With engine running at 1800-2000 rpm, gauge reading should be 220 psi + or - 20 psi. Remove gauge and install air line.

b. Removal

Remove oil pressure line at rear of compressor. Remove air line from check valve. Remove oil return line at engine end. Loosen belt adjusting bolt in generator and remove belt from compressor. Remove compressor bracket bolt. Remove bolts holding compressor support to engine and remove compressor assembly from car.

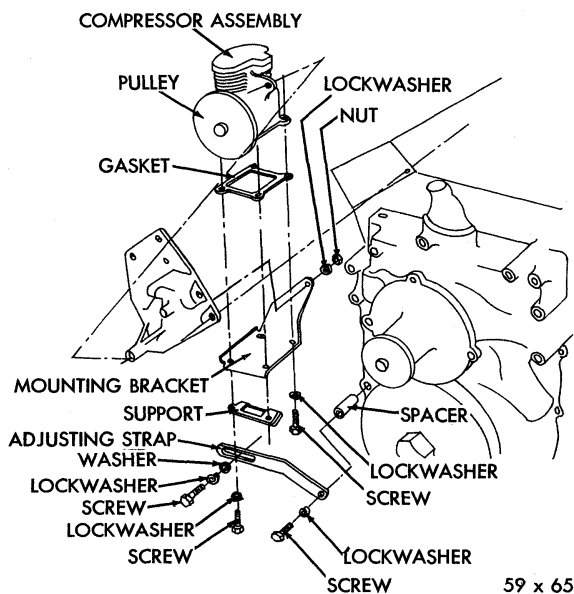

59 x 65

Fig. 15 — Compressor Mounting (with Air Conditioning — Model MC-1)

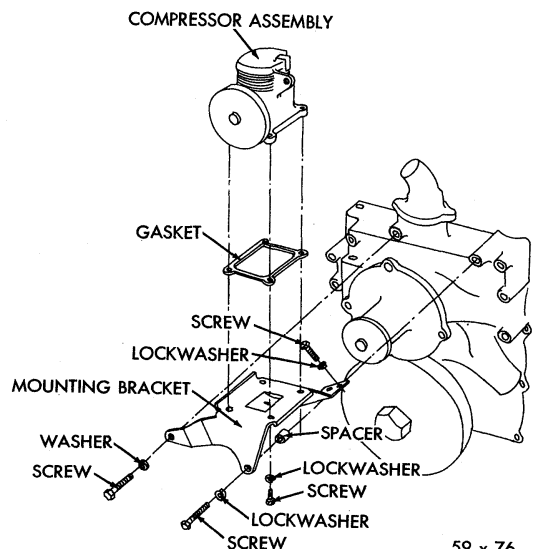

59 x 76

Fig. 17 — Compressor Mounting (without Air Conditioning — All Models)

c. Installation (Figs. 15, 16 and 17)

With compressor attached to support, attach support to engine, tightening bolts to 30 foot pounds torque. Install compressor bracket. Tighten bolt to 30 foot pounds torque.

Install belt (see "Accessory Belt Drives" in this supplement for adjustment). Connect oil pressure line, air line and oil return line. Start engine and check lines for leaks. Test air pressure.

COMPRESSOR RECONDITIONING

The following components parts are available for service:

- (1) Cylinder head and gasket
- (2) Valve plate assembly and gasket
- (3) Pulley and key
- (4) Bottom plate, mounting plate and gasket
- (5) Front bearing, housing and oil seal assembly
- (6) Check valve assembly
- (7) Suction muffler felt

CYLINDER HEAD AND/OR VALVE PLATE ASSEMBLY

Discharge the system. Remove air line from check valve. Remove cylinder head bolts. Remove cylinder head and valve plate assembly. If the plate does not separate from the head, tap the plate lightly with a soft mallet. Do not pry apart.

Clean piston heads, top of the cylinder block and head bolt holes, cylinder head and valve plate, using mineral spirits. Do not use scraper. Inspect pistons and cylinder walls. If damaged, replace the compressor. If valve plate or cylinder head is damaged, replace. Remove check valve only if replacement is necessary.

Use new gaskets when installing valve plate and cylinder head. Tighten bolts to 155 inch pounds

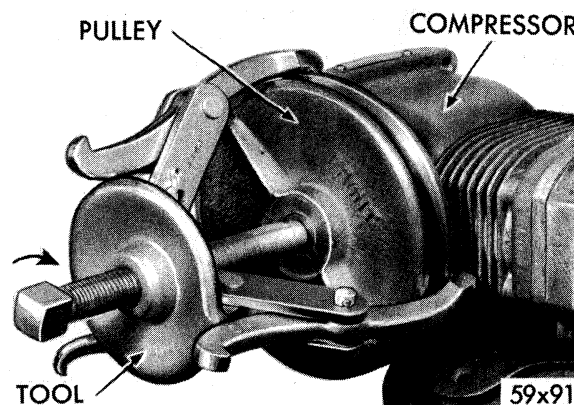

Fig. 18 — Removing Air Compressor Pulley

torque. Connect air line to check valve. Check for leaks and test compressor.

PULLEY AND/OR FRONT BEARING, HOUSING AND OIL SEAL ASSEMBLY

Remove compressor. Original pulley is a .002 press fit on crankshaft. A replacement pulley, in addition, is pinned to the crankshaft. Remove pin before removing pulley. Remove pulley with Tool PO-11 (Fig. 18).

Remove front bearing, housing and oil seal assembly. Clean and inspect bearing and housing assembly. If any component is damaged, replace the assembly. Install front bearing housing, using Tool C-3680 to protect oil seal. Tighten bolts to 17 inch pounds torque.

Remove crankshaft rear cover plate and install Tool C-3677 to support crankshaft while pressing pulley on crankshaft. Using an arbor press, press pulley into contact with flange on crankshaft. Remove tool. Install rear cover plate. Tighten bolts to 17 inch pounds torque.

A new replacement pulley has a hole through one side of the hub. Use this hole as a guide to drill 5/32 inch hole in the crankshaft and the opposite side of hub of pulley. Install the roll pin. Install compressor.

TRUE-LEVEL TORSION AIR SERVICE DIAGNOSIS

CAR DOES NOT MAINTAIN CORRECT HEIGHT POSSIBLE CAUSES

- a. Leaks in System
- b. Incorrect Rear Height Adjustment
- c. Incorrect Front Height Adjustment

UNABLE TO OBTAIN CORRECT HEIGHT POSSIBLE CAUSES

- a. Broken or Pinched Air Line
- b. Leak in Air Spring
- c. Leak in Height Control Valve